

# integrated service modules

chilled beam and service rafts



## System Description

SAS Integrated Service Modules (ISMs), sometimes referred to as Multi Service Chilled Beams (MSCB), have at their heart a passive or active Chilled Beam, which is enclosed by an architecturally designed metal casing.

ISMs integrate various building services such as luminaires, infrared sensors, smoke detectors, fire alarms, voice and data cabling, sprinkler systems and security equipment, such as CCTV.

Chilled Beams use water as the heat transfer method and cooling is provided by the flow of chilled water through the system.

## System Features

- Design led cooling system
- Energy efficient: high operating temperatures
- Integration of services
- Passive or active cooling
- Off-site prefabrication, testing and commissioning available
- Flexible in terms of future room layouts
- Lack of moving parts, resulting in low maintenance regimes
- Facilitates thermal mass cooling
- Compatible with ground-sourcing and free cooling technologies

## Access

Via hinge-down panels.

## Size & Shape

A range of shapes, widths and lengths is available to suit most applications.

## Finish

Polyester Powder coated supplied as standard with a RAL 9010 smooth finish; a fine textured finish (SAS FT), anti-bacterial coating (SAS AB) and other colours are available. See page 36 for a full range of paint finish options.

## Perforation

For optimum performance an open area of 50% is recommended for passive ISMs, while active ISMs require an open area of approximately 63%.

## Weight

Varies depending on size of cooling element, services integrated and whether it is a passive or active ISM.



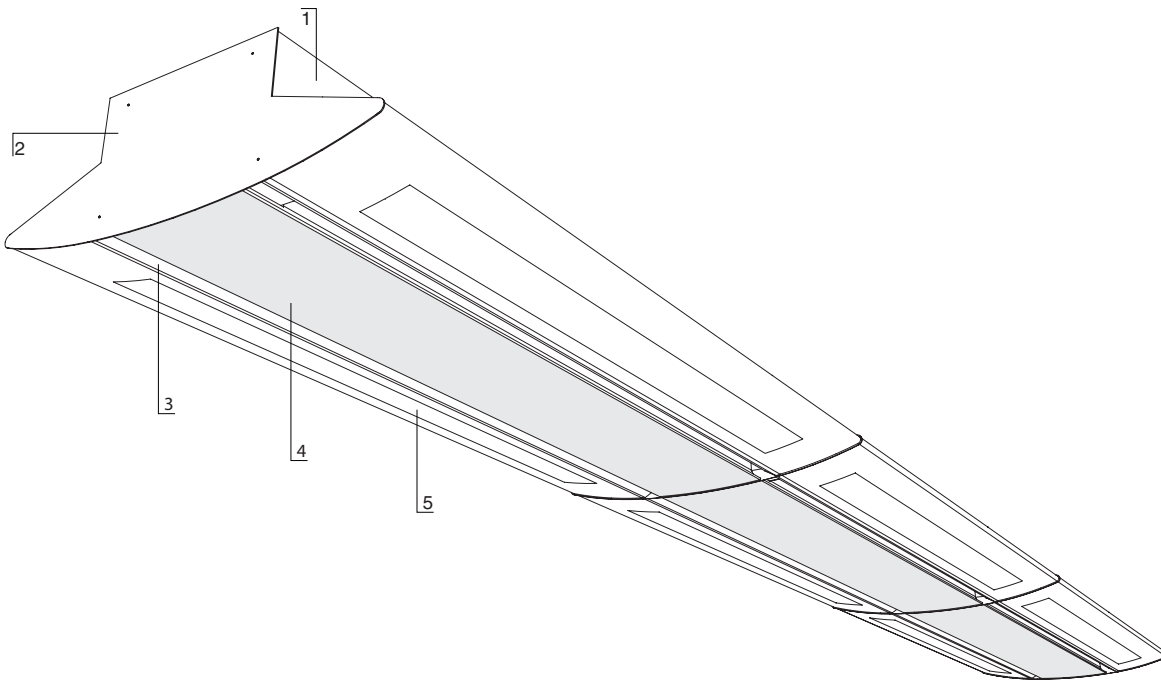

- 1] Active ISM    2] End Plate/Cover    3] Cool (Fresh) Air Supply Vent    4] Perforated Area Allowing Hot Air Access to Chilled Beam  
5] Aperture For Luminaire/MPO Lighting

## Section Drawings

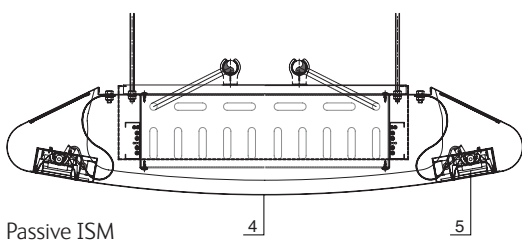

Passive ISM

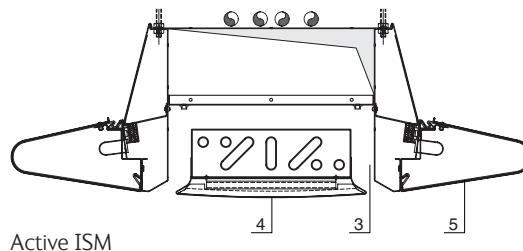

Active ISM

## Performance Data

ISM with Passive Chilled Beam	Cooling capacity (approx).*
Watts per square metre – area (at 3m centres)	130 W/m <sup>2</sup>
Watts per metre (W/m) – length	400 W/m

ISM with Active Chilled Beam	Cooling capacity (approx).*
Watts per square metre – area (at 3m centres)	150 W/m <sup>2</sup>
Watts per metre (W/m) – length	up to 500 W/m

\*Performance is dependant on individual system design.

Further information is available in the Room Comfort brochure or on the SAS website.



## Design & Performance

ISMs are manufactured to meet specific design requirements, as well as strict performance guidelines. They are available in a variety of dimensions and integrate specific building services.

## Legislation

Legislation, including Part L of the Building Regulations (England & Wales), continue to evolve to ensure increases in the energy efficiency of the built environment. ISMs can help to reduce a building's energy usage and carbon emissions.

## Energy Efficient Operating Temperatures

The water supply and return temperatures for ISMs are typically between 14°C and 17°C, which allows for free cooling for parts of the year. Energy consumption is less than other cooling methods.

## Maintenance Costs

Chilled Beams contain no moving parts. The resulting reduction in scheduled maintenance helps reduce the cost of ownership over the life cycle of the product.

## Off-site Prefabrication

Research has proven that the installation of SAS ISMs is 75% quicker compared to traditional installation methods using fan coil units. This can lead to huge savings in labour and associated on-site costs. See page 40 for details on prefabrication.

## Lighting

ISMs can be specified with up or down lighting to meet specific lighting requirements. ISMs can accommodate different luminaire types including MPO (Multi Prism Optic) lighting.

## Planning Grid/ Layout Integration

ISMs are flexible in terms of accommodating future occupant needs, such as partitioning. Module lengths and widths, along with the incorporation of in-fill panels facilitate the reconfiguration of the space at a future date.

## Thermal Mass Cooling

The specification of ISMs offer the added benefit of opening a concrete soffit for thermal mass cooling. This is a natural process, which absorbs heat during the day and releases it at night when it is not required. This method has the potential of producing a cooling output of 25 W/m<sup>2</sup>, see page 43.

## Comfort Cooling

ISMs generate minimal air movement and noise, especially when compared to mechanical alternatives, increasing occupant comfort and potentially increasing productivity.

## Additional Information

Further information on the range of SAS ISMs can be found in the Room Comfort brochure.